

Secondary glazing

Secondary Glazing

The installation of secondary glazing has in recent years become a popular requirement for our homes. Some of the advantages include; noise insulation, especially when habitable rooms face busy roads; heat insulation, cutting down on our heating bills; and home security.

With so many window types there cannot be a standard solution. However when considering the installation of a secondary system the following factors should be taken into account:

- The effectiveness of secondary glazing is influenced by the size of the cavity between panes. The minimum gap normally required is 100mm.
- Sound insulation increase with the thickness of glass. The secondary window must comprise of glass heavier than the existing window.
- Weather sealing should be provided to both leaves.
- The side reveals between the window leaves should be lined with sound absorbent material.

Installing secondary glazing

In most cases secondary glazing can be installed using one of a number of proprietary systems without affecting the existing window. However, if it is not practicable to provide the minimum air gap between window leaves, it will become necessary to replace the existing windows with either new single glazed units and secondary glazing or special high performance double/triple glazed units, which can also provide thermal insulation.

The installation of secondary glazing may cause ventilation problems, which can be overcome by the use of acoustic vents or acoustic brick. Where rooms are heated by or contain gas appliances it is essential that adequate ventilation is maintained. The Gas Board will advise on minimum air changes if required.

Is your building listed or in a conservation area?

If your building is listed or in a conservation area it is necessary to consider the visual impact of new glazing units.

Typical secondary glazing

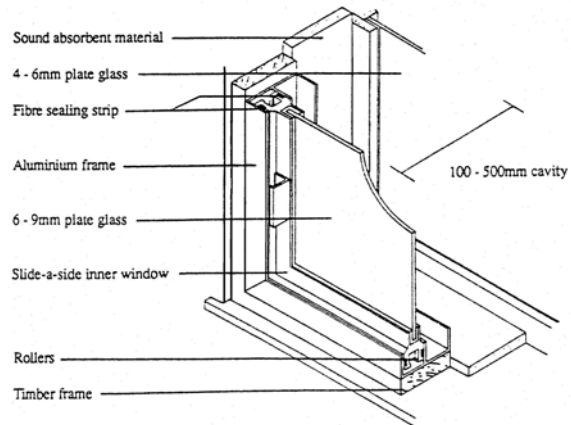

You can contact a planning officer at Planning Services

Civic Offices
Guildhall Square
Portsmouth
PO1 2AU

Telephone: 023 9283 4334
Fax: 023 9283 4660
e-mail: planning@portsmouthcc.gov.uk